

Better life
with steel

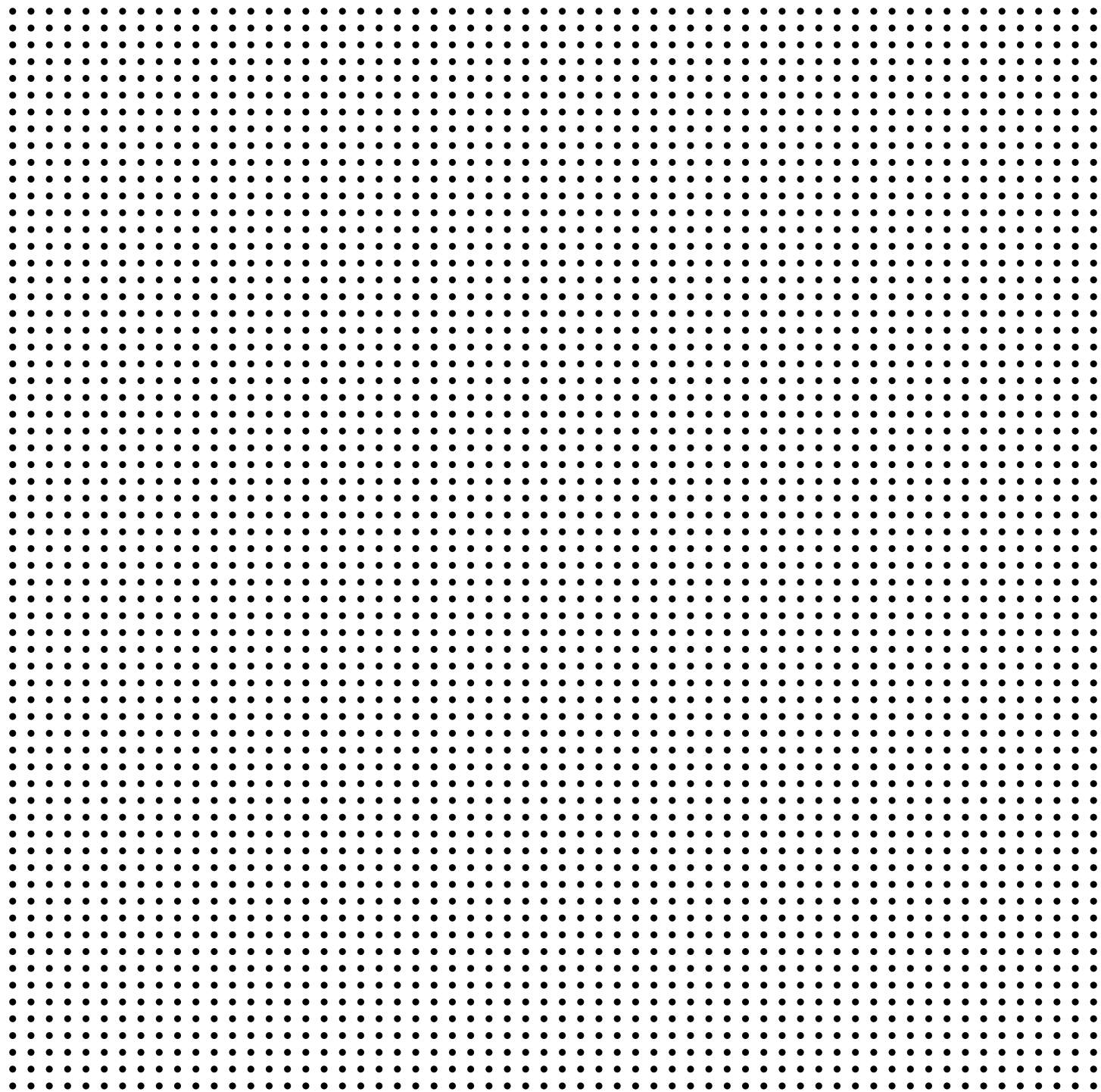



CONTENTS

06 CEO Message

12 CSP

38 Subsidiaries

45 Social Contribution

08 History

14 Product introduction

40 Global Network

46 Environmental
Management Activities

10 Capacity

28 Company Network

44 Sustainable Management

48 Contact

We create Better life with Steel

Making a better world through steel...

Steel is cyclical.

Steel, it's more than 90% recyclable. repurposing scrap metal into new steel products using an electric furnace, Dongkuk Steel is a forerunner in striving for a sustainable and cyclical society.

Steel is durable.

Steel, it's trusted for dependable durability. By supplying our dependably strong steel for buildings, bridges, shipping vessels, and railways, we promote a society that's safer for us all everywhere we go.

Steel is breathtaking.

Steel, it's absolutely versatile. By applying the right amount of heat and/or color, Dongkuk Steel adds beauty within our lifestyle, whether it be through interior spaces, home appliances, or furniture fixtures.

We believe that the steel we produce is the backbone from which our society is built upon and it enhances life's values; with this sense of pride, we continue to improve upon our steelwork to maintain the trust of our customers

CEO Message

Message from the Chairman

Dongkuk Steel's 'Pioneer Mindset' has contributed towards the Korean Steel Industry's greatest moments.

As Korea's very first privately-owned steel manufacturer, Dongkuk Steel has always retained the life of steel with pride of being a major part of Korea's national industry.

Our humble beginnings span back to when we first fired our furnace and became the first private company to manufacture wire rods, which were critical in rebuilding our nation's infrastructures. Through fervid investment, we helped herald the industry's now commonplace usage of electric furnaces and diversified our portfolio to include cold-rolled carbon steel, steel plates, electrolytic galvanized steel, and pre-painted steel products.

Dongkuk Steel's many firsts were possible only through our enduring passion towards the industry and the fearless spirit of challenge in facing any and all failures that came our way. For instance, our ardent passion in reclaiming land from the shores of Yongho-Dong, Busan has since reached the shores of other nations, as we embark on a new expansion project through Brazil's CSP manufacturing plant.

As proven by our track records, Dongkuk Steel will always remain the "first mover." All of our experiences and wisdom we've gained throughout the years will surely aid us in looking forward toward the next hundred years of industry.

Chairman of Dongkuk Steel
Sae-joo, Chang



Message from the Vice Chairman

Dongkuk Steel is headed towards future innovation

Dongkuk Steel has a proud history of achievements over the last half century and has created products and services that improve people's quality of life.

We believe the driving force of the company is not staying in the past but resolutely moving towards the future.

Rather than being complacent with the pride of having created the best products, Dongkuk Steel has been putting forth the utmost effort to innovate in all its corporate activities.

It overcame preconceptions about steel marketing by launching a premium pre-coated metal brand, Luxteel. It was also the first in Korea to introduce the eco-arc furnace and proposed an eco-friendly electric furnace business model by commercializing hot charge engineering technology to maximize energy efficiency.

Dongkuk Steel's innovations are intended for humanity.

The spirit of labor-management harmony, which has been continually growing since 1994, is now spreading throughout all of the company's business areas.

Dongkuk Steel is striving to be an enterprise that is dedicated to not only its employees, but also its investors, the stakeholders, and local communities as well, not to mention all others related to the company's corporate activities.

Keep an eye on Dongkuk Steel as the company grows into an innovative enterprise beyond a steel company.

Vice Chairman of Dongkuk Steel
Sae-wook, Chang



History of the First Innovations

Writing new chapters in history as the first.

The history of Dongkuk Steel and the path it took has led to one milestone after another. Since beginning as Korea's first private steel manufacturer, these brilliant milestones have helped modernize the Korean steel industry, Dongkuk Steel's innovations and challenges will continue for improving the lives of all humankind and cultural evolution.

1954~1969

- **1954**
Foundation of Dongkuk Steel
- **1959**
Became the first in Korea to produce wire rod
- **1963**
First private company to build a large-scale steel plant (Yongho-dong, Busan)
- **1965**
Became the first in Korea to start blast furnace operations
- **1966**
Became the first in Korea to start electric furnace steel factory operations (designated a modern cultural heritage)
- **1967**
Became the first in Korea to produce cold rolled steel

1970~1999

- **1971**
Became the first in Korea to produce steel plates
- **1972**
Began operations of Incheon Works
Became the first in Korea to produce pre-coated metal
- **1986**
Became the first in Korea to start electrolytic galvanized line (EGL) operations
- **1988**
Initial public offering
- **1993**
Became the first in Korea to start using direct current electric arc furnaces
- **1994**
Became the first in Korea to establish permanent no-strike agreement with labor union
- **1997**
Began operations of Pohang Works No. 2 steel plate factory
Began operations of Pohang Works sections factory

2000~2010

- **2001**
Chang Sae Joo took office as chairman
- **2005**
Established the Central Research Institute of Technology
- **2007**
Began operations of Busan Works PL-TCM line
- **2010**
Began operations of Dangjin Works
Began eco-friendly arc furnace operations at Incheon Works
Pre-coated metal for home appliances were selected as a World Class Product of Korea

2011~2016

- **2011**
Launched Luxteel, Korea's first steel brand
Became the first in Korea to obtain the KS mark for seismic-resistant steel
- **2012**
Began operations of a rolling factory at Incheon Works (Rolling Factory No. 1) with the highest line speed in Korea
- **2015**
Merged with Union Steel
- **2016**
Fired the blast furnaces at CSP Steel Mill in Brazil
Became the first in Korea to commercialize digital printing of steel plates
Completed Busan Works No. 9 color coating line (CCL)

2017~2019

- **2017**
Achieved cumulative colored steel sheet production of 10 million tons
Dangjin Works received the first batch of slab from CSP Steel Mill in Brazil
- **2018**
Became the first in Korea to produce seismic-resistant coil steel
Launched DK Deck, a patterned H-beam brand
Became the first in Korea to produce anti-bacterial pre-coated metal
Began operating the Doseong Center in Dangjin
- **2019**
Became the first in the steel industry to obtain an integrated environmental permit
Became the first in the world to apply pre-coated metal (PCM) to furniture

Capacity

Dongkuk Steel produces 8.18 million tons of steel products annually which are used for reinforcing our ways of life and making our cultural experiences more bountiful.

Steel scrap are melted and repurposed into rebars, sections, and steel plates, which are released back into the world to form the frameworks of our society.

We produce products such as Galvanized and pre-painted steel sheets that add luster and glamor within our lives.

Total 8.18 million tons

Businesses		Production capacity (10,000 tons/year)
Hot rolled steel	Steel plates	150
	Reinforcing bars	275
	Sections	130
Cold rolled steel	Galvanized steel	188
	Pre-coated metal	75
Total		818



Steel making

3.6 million tons

Hot rolled steel



Steel plates

1.5 million tons



Reinforcing bars

2.75 million tons

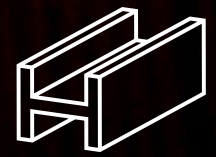

Sections

1.3 million tons

Cold rolled steel



Galvanized steel

1.88 million tons

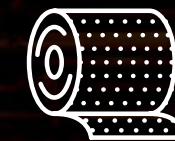

Pre-coated metal

750 thousand tons

Golden steel belt Connecting Korea & Brazil

Dongkuk Steel established the
“Golden Steel Belt” connecting Korea and Brazil.

CSP (Companhia Siderúrgica do Pecém)

A “steel complex of dreams” that was created through abundant capital and advanced technology

Dongkuk Steel achieved integrated steel making by building a blast furnace steel mill with an annual production capacity of 3 million tons at Pecém Industrial Complex in Ceara, Brazil through CSP, a joint venture established with POSCO and Vale. With the Golden Steel Belt connecting Korea and Brazil, Dongkuk Steel will expand its market across the world to Europe as well as to North, Central, and South America.

Overview of Dongkuk Steel’s CSP Steel Mill in Brazil



Scale

Site: Approx. 980 ha
(equivalent to 1,372 standard FIFA football fields)



Production

Capable of producing 3 million tons of slab a year



Shareholder

Dongkuk Steel (30%),
POSCO (20%), Vale (50%)



Sales

Exports to 12 countries around the world



Total No. of Employees

Approx. 2,400



Certifications

Certification by 8 classification institutions
(ABS, BV, DNVGL, KR, LR, NK, RINA, RS)

History of Dongkuk Steel’s CSP Steel Mill



2005

Investment started



2012

Construction started



2016

Production commenced through the initial firing of furnace



2018

Achieved full production

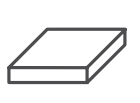

2020

Achieved slab production of 10 million tons

Product introduction

To make steel new and more valuable to the world, Dongkuk Steel is creating differentiated steel products based on its advanced technology and expertise accumulated over a long period of time.

01 Steelmaking / Continuous Casting

02 Reinforcing Bars

03 Sections

04 Steel Plates

05 Cold rolled & Galvanized steel

06 Pre-Coated Metal



Steelmaking Continuous Casting

Product

Steel making/Continuous Casting

Iron is an eco-friendly material that can be recycled at a rate exceeding 90%. Dongkuk Steel produces molten metal, which is used in a wide range of steel products. This is done by applying an electric furnace that uses steel scrap as a recyclable material. When steel scrap is put into the electric furnace, it is melted down into molten metal with high-temperature arc heat. Through the continuous casting process, molten metal is turned into semi-finished products, such as billets, blooms, and beam blanks. These semi-finished products are then used in producing reinforcing bars and sections.

Eco-Arc Electric Furnace

This is an eco-friendly electric furnace that can be continuously charged with steel scraps while maintaining the ability to melt iron into molten metal. It preheats steel scraps on standby for insertion using heat generated in the course of operation, and thus reduces the amount of energy consumed by 30% when compared with existing techniques. The effective energy savings lead to lowered CO₂ emissions, and thus contribute to cutting down on greenhouse gases.

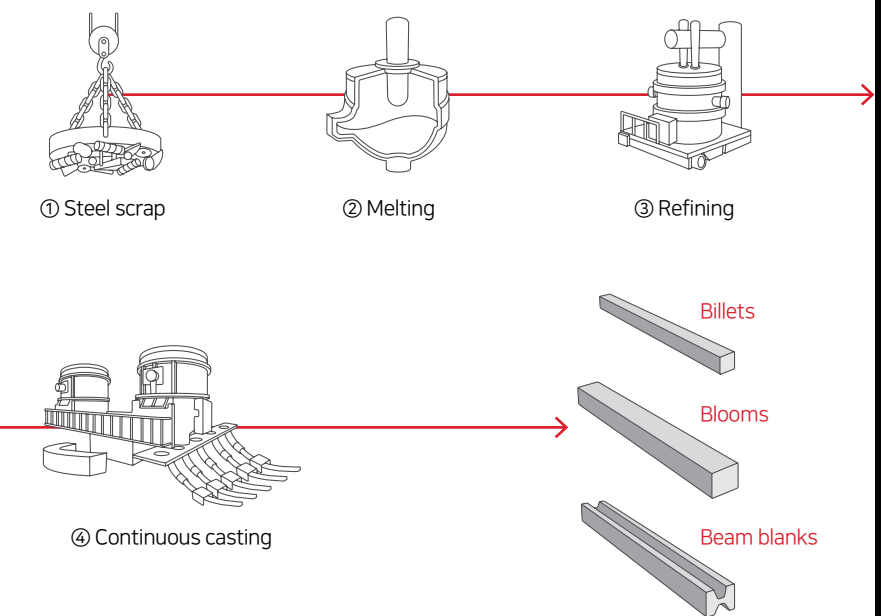



Reinforcing Bars

Product

Reinforcing Bars

Reinforcing bars are a steel material that is widely used in building and engineering projects, such as in the construction of apartment buildings. Dongkuk Steel produces general, high tension, and super hightension reinforcing bars in various sizes ranging from D10 (10mm) to D57 (57mm) from Incheon Works and Pohang Works. In addition, Dongkuk Steel was the first in Korea to successfully obtain the KS mark for seismic resistant reinforcing bars, and thus leading the market.

Seismic Resistant Bars

Seismic resistant bars are a special product that can withstand impact and vibrations caused by earthquakes. It increases the stability of a building's structure, and thus prevents the sudden collapse of the building in an emergency situation, securing time for evacuation.

DKOIL

DKOIL is Dongkuk Steel's coil-type reinforcing bar brand. This is a product created by processing steel bars measuring as long as 6.2km into the shape of a coil. With convenient loading and processing and a low loss rate, DKOIL has garnered a lot of attention at construction sites. Dongkuk Steel strengthened its competitive power by recently becoming the first in Korea to develop and commercialize seismic resistant coil reinforcing bars.

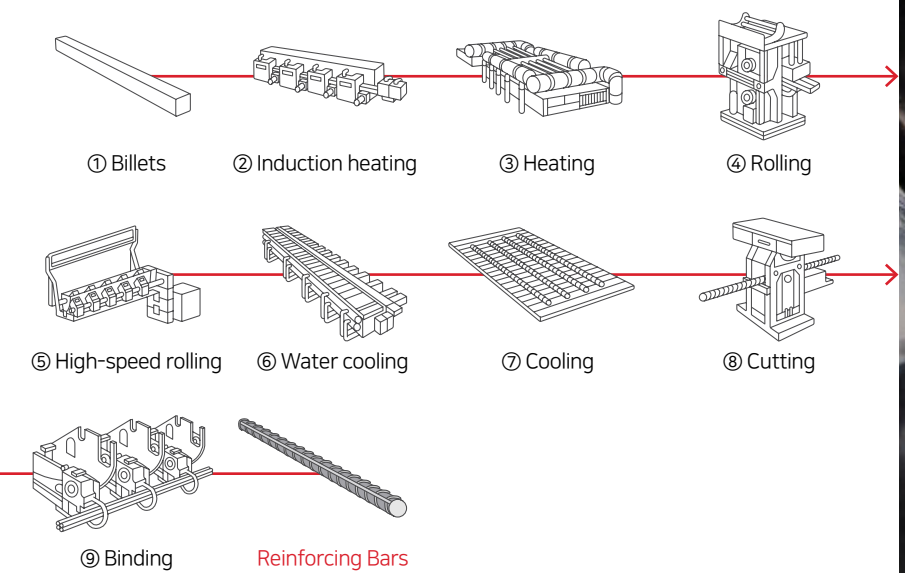

Sections

Product

Sections

Sections, such as H-beams, angles, and channels, are structural steel materials that are used on industrial sites for building and engineering projects as well as machine and steel tower manufacturing. Dongkuk Steel is producing a variety of sections including H beams, angles, channels, flat bars, and profiles at both Pohang Works and Sinpyeong Works.

Seismic Resistant H Beams

Seismic resistant H beams come with improved performance with regards to their ability to withstand external impact caused by earthquakes, etc. They can be applied to the construction of steel-frame high-rise buildings. Recently, the demand for this product has been steadily increasing as a result of frequent earthquakes in Korea and abroad.

DK-Deck

DK-Deck is an H-beam with a variety of patterns embossed on its surface. It is used in the production of road decking plates for construction sites. Compared to channels, which have also been used in the production of road decking plates, DK-Deck has superior performance with regards to its ability to withstand loads. In addition, the embossed pattern increases the coefficient of friction, and thus improves safety.

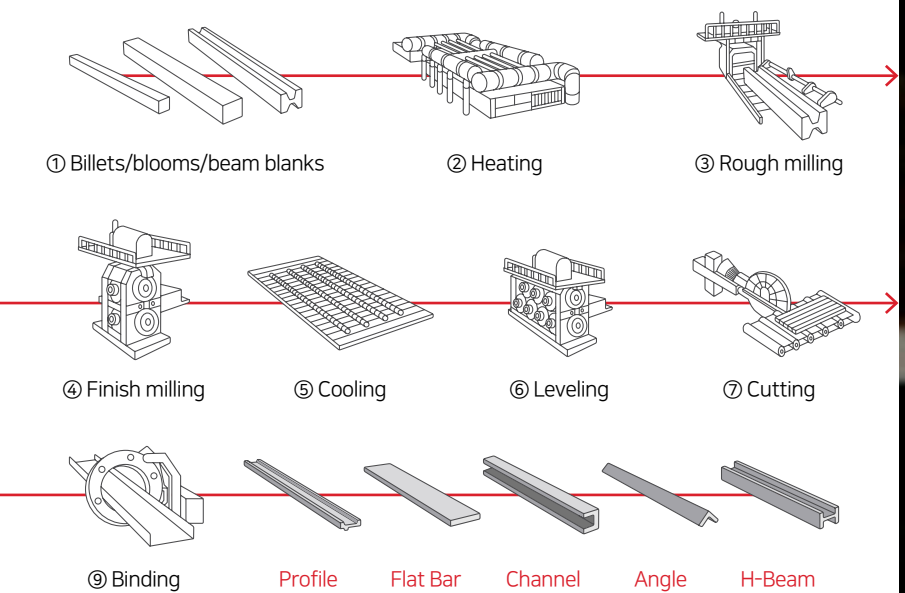



Steel Plates

Product

Steel plates

Steel plates, plates measuring at least 6mm in thickness, are used on ships, buildings, bridges, pipes, boilers, and pressure vessels. With its expertise and technological competence accumulated over a long period of time, Dongkuk Steel which was the first in Korea to produce steel plates manufactures steel plates of various grades, such as general, heat-treated, or TMCP products, and with a wide range of specifications including extra-thick, extra-thin, and wide thick plates for shipbuilding.

DK-LP Plate

DK-LP is a steel plate created by rolling a plate lengthwise into different thicknesses. Compared to the process of welding steel plates of different thicknesses and applying them to a structure, using DK-LP ensures greater stability and saves time and money for processing.

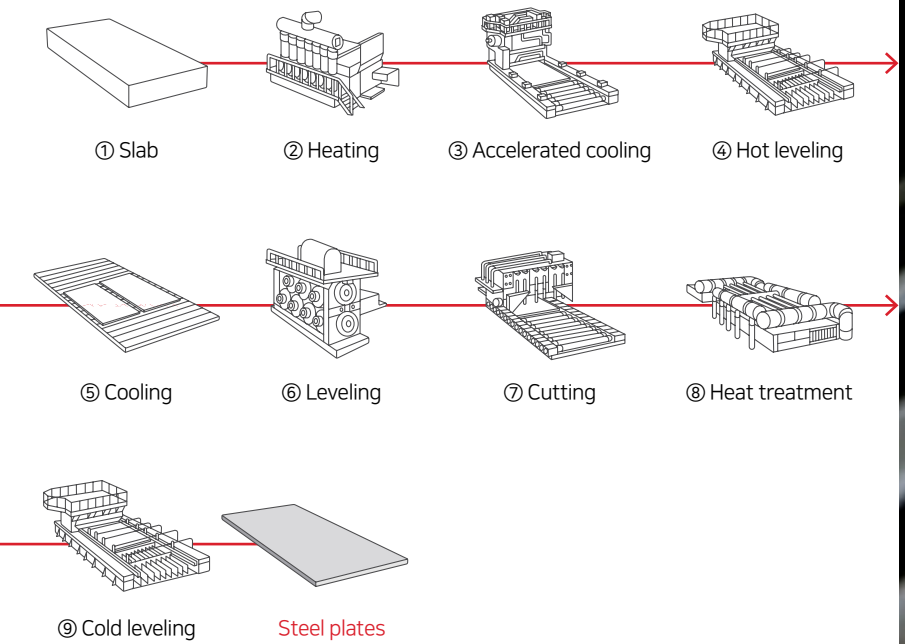

05

Cold rolled & Galvanized Steel



Galvanized Steel

These steel plates are created with Dongkuk Steel's top-tier coating technology. With a neatly finished surface and excellent corrosion resistance, galvanized steel is used in the production of interior and exterior materials for structures, automobiles products, and as a pre-coated metal.

GI (Galvanized Steel)

Created using the characteristics of zinc, this product provides excellent corrosion resistance, coatability, and workability. The amount of coating can be modified as necessary. The amount of coating can be modified accordingly. This product is used in internal or external plates for building materials, office equipment, fire doors, and home appliances.

GL (Galvalume Steel)

Al-Zn alloy galvanized steel product is made through the optimal synergy between the strengths of zinc and aluminum. These strengths are durability, heat resistance, and alkali/acidity resistance. Galvalume steel is used in materials for roofs, walls, and pipes.

EGI (Electro Galvanized Steel)

Electro galvanized steel is created by electrolytically coating steel plates with zinc. Because the mechanical properties of the material are maintained through this process, the product quality is not deteriorated even for molding and processing. Furthermore, electro galvanized steel provides excellent weldability. This product is used for home appliances and as interior and exterior material for buildings.

GIX / GLX (Mg Alloy Galvanized Steel)

This product is created by alloying aluminum, zinc, magnesium, and silicon at the optimal ratios and hot-dipping steel plates in the alloy. It is used for various purposes that require high corrosion resistance.

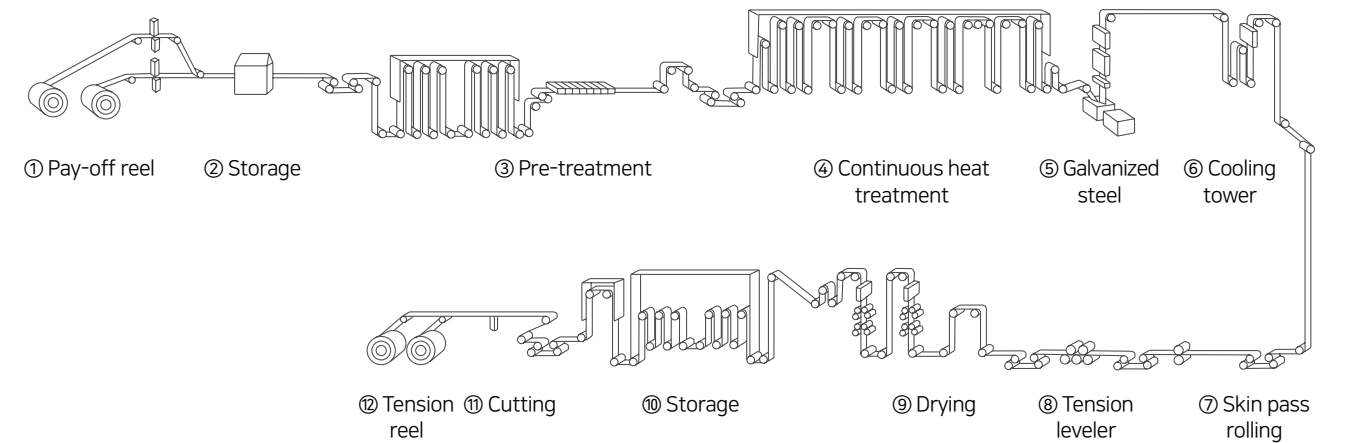

06

Pre-Coated Metal

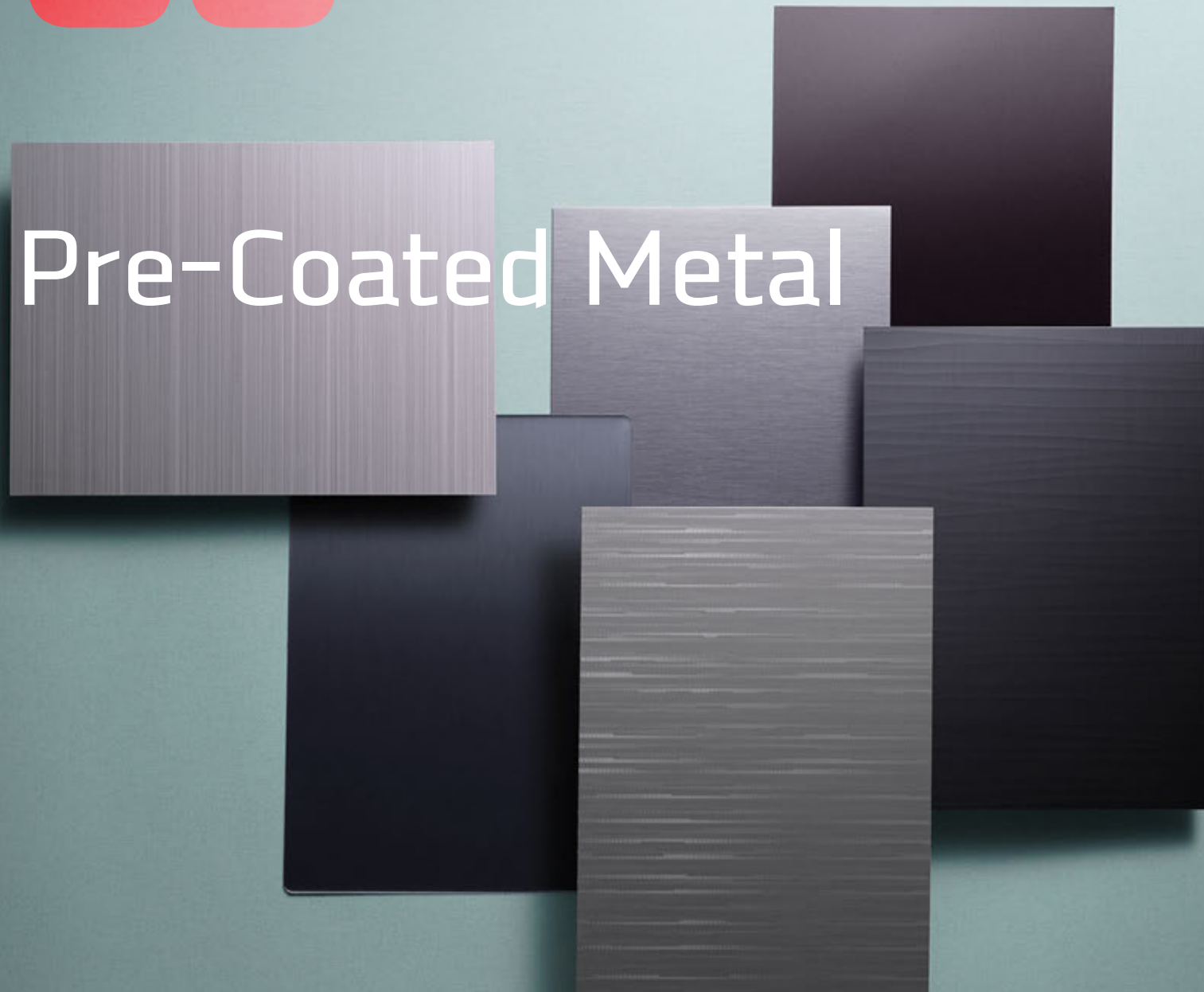

Pre-Coated Metals

Having been the first in Korea to produce pre-coated metal, Dongkuk is equipped with the world's largest pre-coated metal production capacity based on a single plant. Dongkuk Steel, which supplies world's highest quality pre-coated metals with various design patterns and surface textures, is leading the global pre-coated metal market based on its extensive product portfolio that covers not only digital printing plates to which photo-like clear printing technology is applied, but also antibacterial pre-coated metals.

Luxteel

This is a premium pre-coated plate brand for interior and exterior construction materials with elegant patterns and colors strictly selected by leading architects. Using a highly weather resistant coating materials, Luxteel products are effective against discoloration caused by exposure to the outdoor environment. In addition, the use of GIX and GLX materials ensures corrosion resistance over a long period of time. Based on these strengths, Luxteel increases customers' choices when selecting natural building materials.

Appsteel

Selected as a World Class Product of Korea, Appsteel is a premium pre-coated metal brand for home appliances. With its beautiful patterns, excellent workability, and strict quality controls, Appsteel is recognized for its quality in the global pre-coated metal market for home appliances.

supersmp

Supersmp is a pre-coated metal for panel and roof materials which is created to set a new standard for pre-coated metal products in Korea. Produced under strict quality controls in compliance with the recently amended Building Act, supersmp products are created with a highly weather resistant material that is effective against discoloration. In addition, the anti-dust and cool roofing functionalities have been optimized for use in external panels.

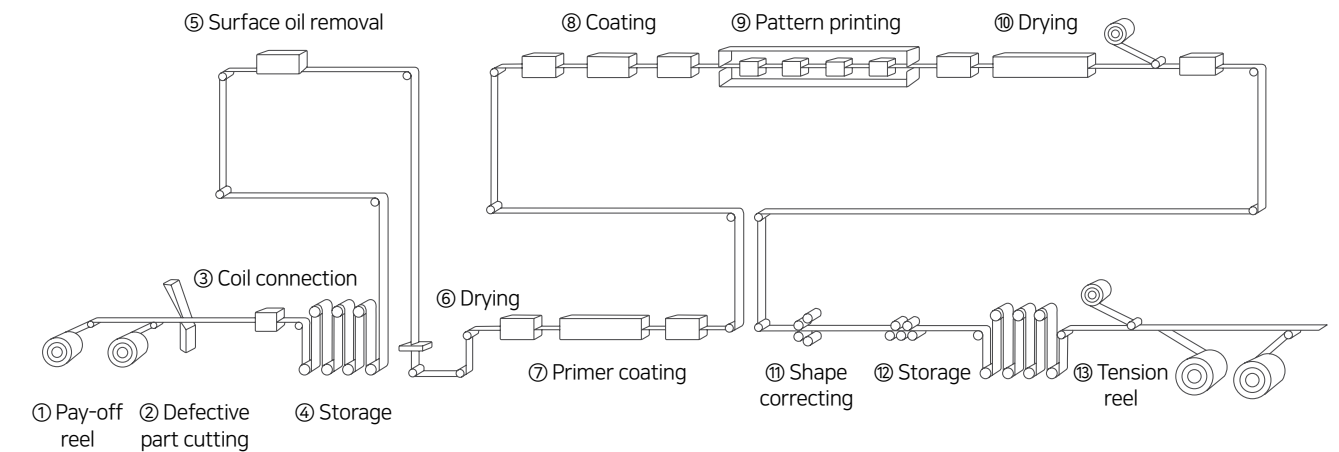

Company Network

Dongkuk Steel is improving its competitiveness by establishing domestic and international networks.

- 01 Seoul Head Office
- 02 Incheon Works
- 03 Pohang Works
- 04 Sinpyeong Works
- 05 Dangjin Works
- 06 Busan Works
- 07 Doseong Center
- 08 R&D Center
- 09 Subsidiaries
- 10 Global Network





Seoul Head Office

Dongkuk Steel's Control Tower: Head Office (Head Office in Seoul)

Located in Suha-dong, Jung-gu, Seoul, the head office of Dongkuk Steel plays the role of a control tower. It is comprised of Financial, Management Support, and Strategy Development Division which they help ensure internal stability for the company and discover new growth engines for the company's businesses. The Marketing Division analyzes market trends and suggests new directions. The Business Division strives to effectively respond to customer needs and promote development in new markets. Dongkuk Steel's head office has established the 'smart office' with a goal to promote dynamic and creative organizational culture by improving the employee work efficiency and enhancing their quality of life.



Incheon Works

Eco-Friendly Reinforcing Bar Production Plant: Incheon Works

Incheon Works is Dongkuk Steel's main production plant for reinforcing bars. Having achieved the world's highest volume of steel production per hour in 1986 and being the first in Korea to introduce the DC electric arc furnace in 1993, Incheon Works is a plant with great potential that has hit many milestones in the history of the Korean steel industry. In 2010, Incheon Works was the first in Korea to introduce an eco-arc furnace, and thus was reborn as an eco-friendly plant with improved energy efficiency and minimized pollutant emissions. The new rolling plant began operations in 2012 and is equipped with the world's highest efficiency, based on its ability to roll 42m of iron bars per second (based on D10).

Overview of Incheon Works

- Total Floor Area 141,550㎡
- 2 electric furnaces/2 reinforcing bar rolling lines
- Products : Seismic resistant bars, nuclear bars, LNG bars, thread bars.



Annual Production Capacity of Incheon Works (10,000 tons/year)

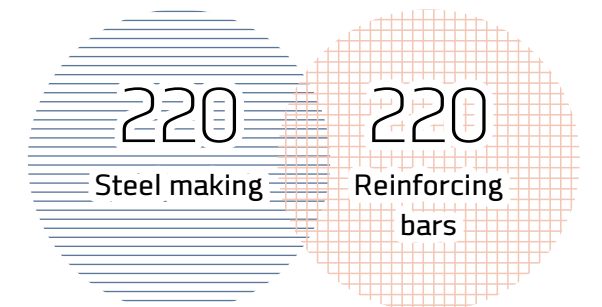



Pohang Works

The Leader of the Second Revolution: Pohang Works

Pohang Works is the leader of Dongkuk Steel's second revolution. It continuously promotes change and pursues innovation by introducing state-of-the-art technologies and improving facilities. Having maximized productivity by being the first in Korea to introduce a twin-vessel electric furnace and EBROS (endless bar rolling system), Pohang Works produces reinforcing bars and sections with optimal efficiency. In addition, it is leading changes in the market by manufacturing special products including seismic resistant H beams, patterned H beams, and thread bars.

✓ Overview of Pohang Works

- Total Floor Area 837,860㎡
- 1 electric furnace/1 section rolling line/1 reinforcing bar rolling line
- Products: Seismic resistant H beams, patterned H beams, coil bars, seismic resistant bars, nuclear bars, LNG bars, thread bars.

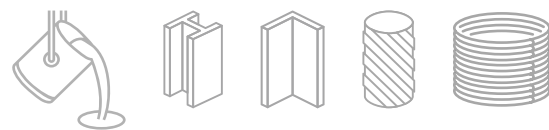

Annual Production Capacity of Pohang Works (10,000 tons/year)

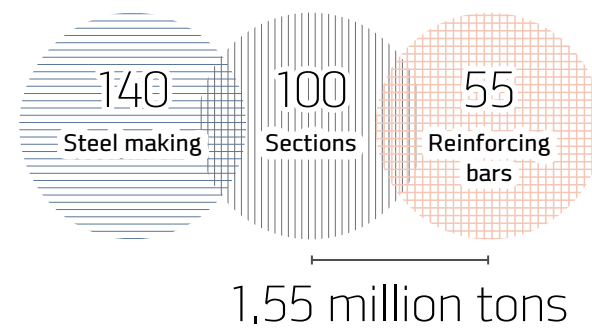

Sinpyeong Works

A Plant Specializing in Multi-type Small and Medium-size Sections: Sinpyeong Works

Sinpyeong Works is producing multi-type small and medium-size sections to meet the varying needs of customers. The ordinary versions of the channels, angles, flat bars, profiles, and round bars manufactured at Sinpyeong Works are used for various purposes, such as engineering projects, machine/facility/steel tower manufacturing, and as subsidiary materials for construction. As a small but robust plant full of craftsmanship and passion, Sinpyeong Works is the pride of Dongkuk Steel and represents the company's tradition.

✓ Overview of Sinpyeong Works

- Total Floor Area 18,694㎡
- 1 section rolling line
- Products: Channels, angles, flat bars, profiles, round bars

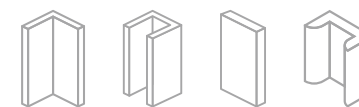

Annual Production Capacity of Sinpyeong Works (10,000 tons/year)





Dangjin Works

A Strategic Production Base for Premium Steel Plates: Dangjin Works

Dangjin Works, of which the construction was completed in 2010, produces not only general steel plates, but also premium products used in special ships, marine structures, and large-scale ships. As the percentage of premium products is high, Dangjin Works is equipped with a RTLS (real time location system), which enables real time verification of the status of raw materials and semi-finished products; a precision control system which ensures TMCP manufacturing through slab rolling and cooling at exact temperatures and pressures; and other advanced systems developed through a combination of IT and steel manufacturing technologies.

✓ Overview of Dangjin Works

- Total Floor Area 687,600m²
- 1 steel plate rolling line
- Products: Steel plate for shipbuilding certified by classification institutions in nine countries, TMCP steel plates, DK-LP plates with varying lengthwise thicknesses.



Annual Production Capacity of Dangjin Works (10,000 tons/year)



Busan Works

World's No. 1 Pre-Coated Metal Plant: Busan Works

Busan Works has the world's highest pre-coated metal production capacity based on a single plant. It produces Dongkuk Steel's highest value-added products. Having been the first in Korea to succeed in producing pre-coated metal (1972), galvalume steel (1986), and electro galvanized steel (1986), Busan Works has solidified its position as a production base for surface-treated steel plates over a long period of time. It is leading the global pre-coated metal market by manufacturing a range of premium products including Luxteel, a premium pre-coated metal for interior and exterior materials; Appsteel, a pre-coated metal for home appliances; and supersmp, a highly weather resistant single-colored pre-coated metal, which have all been developed and launched on the basis of Dongkuk Steel's expertise and unrivaled technological power.

✓ Overview of Busan Works

- Total Floor Area 353,329m²
- 8 pre-coated metal lines/6 galvanized steel lines/ 1 PL-TCM line.
- Products : Luxteel, Appsteel, supersmp, GIX/GLX

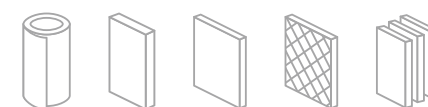

Annual Production Capacity of Busan Works (10,000 tons/year)

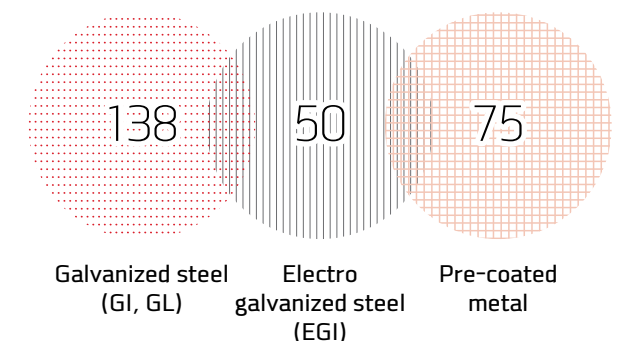



Doseong Center

A State-of-the-Art Steel Processing Center: Doseong Center

Located in Dangjin, Chungcheongnam-do, the Doseong Center is equipped with state-of-the-art steel processing facilities. Doseong Center began its operations in 2018 and supports the processing of pre-coated metal (Luxteel) products and field construction projects. Doseong Center, which manufactures a wide range of products, including line panels, fire doors, metal panels, and steel curtain wall systems, improves customer satisfaction by applying optimized processing technologies to Luxteel products. In addition, it has quick delivery and zero errors thanks to its innovative improvements on prior processes, thus it presents a new direction for steel as an interior and exterior material for building structures.

✓ Products

Luxteel FIRE DOOR



Luxteel LINE PANEL



Luxteel METAL PANEL

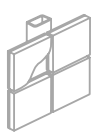

Luxteel CURTAIN WALL



✓ Doseong Center's Differentiated Competitive Power

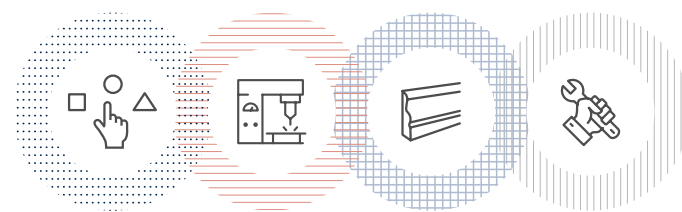

Capable of producing multi-type items in small quantities

Capable of producing items with large dimensions

Non-structured processing

Product design support

R&D Center

The Home of New Product/Technology Development: Central Research Institute of Technology

Established in 2005, the Central Research Institute of Technology is Dongkuk Steel's advanced base that produces the company's future growth engines by integrating steel-related knowledge and information and accelerating R&D for new product and technology development. Following the principle that R&D must be conducted in close connection with production sites, the departments dedicated to researching steel making, reinforcing bars, and sections are located in Pohang and those dedicated to researching pre-coated metal and materials (cold rolling/coating) are located in Busan.

The department researching steel making specializes in R&D related to steel making, refining, continuous casting, and refractories. It promotes research for the production of the highest-quality molten metals. The department researching reinforcing bars and sections focuses on roll design, alloy design, and thermodynamic analysis. It pursues the development of new products and new steel types for reinforcing bars and sections, such as seismic resistant steel materials. The department researching pre-coated metals is dedicated to conducting research that will lead to new value-added products; such as Appsteel, the pre-coated metal for home appliances; Luxteel, the premium pre-coated metal for construction materials; and other special-purpose pre-coated metal products. The department researching materials pursues the development of a range of heat treatments and coating technologies as well as new products in relation to the production of cold rolled steel and coated steel, which are used for pre-coated metals.

✓ Key Facilities of the Central Research Institute of Technology

- Pohang

- Steel making and Refining: Vacuum melting furnace, etc.
- Hot Rolling: Pilot hot roller
- Physical Properties Test: Tension tester, etc.
- Welding Test: EGW, etc.
- Analysis Equipment: FE-SEM, EPMA, XRF, XRD, ICP, spectr

- Busan

- Physical Properties Test: Tension tester, accelerated weathering tester, salt spray tester, thermo-hygrostat
- Moldability Test: Multipurpose plate molding tester
- Hot Dipping: Hot dipping simulator
- Electroplating: BAF heat treatment tester, electroplating device
- Pre-Coated Metal: Heat treatment oven, UV hardener, emboss roll pilot, spectrometer, gloss meter
- Analysis Equipment: FE-SEM, EDX, EBSD, GDS, XRD, 3D surface profiler



A Value-Creating Total ICT Solution Provider: Dongkuk Systems

Dongkuk Systems is a total ICT solution company which develops and provides system integration and management services as well as IT solutions for various industrial sectors. Launched as Dongkuk Steel's IT service provider in 2005, Dongkuk Systems declared its new vision of transforming into a total ICT solution provider with the highest level of competitiveness in 2019. Under this new vision, Dongkuk Systems is providing the best products and services for customers so they can innovate their businesses. Dongkuk Systems is expanding its business to target not only Dongkuk Steel and its affiliates, but also a variety of customers from manufacturing, public, financial, and educational sectors. Amid the rapidly changing management environment, it supports IT-based business process innovation. In addition, Dongkuk Systems has established partnerships with global IT companies including HP Korea, IBM Korea, and Nokia and is providing differentiated IT solutions, such as servers, storage, network equipment, and software products optimized to fit the managerial environments of customers.



An Infrastructure Company that Supports the Business of Dongkuk Steel's Affiliates and Operates the Ferrum Club: Ferrum Infra

Ferrum Infra is a company specializing in infrastructure development and it handles and supports various infrastructure projects of Dongkuk Steel and its affiliates. It provides the best purchasing service to Dongkuk Steel and external customers by operating the MRO system, an integrated system for the purchase of consumable materials. Based on the system, Ferrum Infra provides support for work load reductions and process improvements. In addition, it operates Ferrum Club, an eco-friendly golf course established in a natural setting. As such, Ferrum Infra extends the reliability of Dongkuk Steel's brand.



Subsidiaries

A Logistics Company with the Highest Level of Competitiveness: INTERGIS

Established in 1956, INTERGIS strives to meet the customers' various needs by providing comprehensive logistics services including port cargo handling, land transportation, marine transportation, international logistics, and customs processing and storage based on its network that covers major ports and logistics bases in Korea. At the same time, based on the experiences and business expertise built into the Korean market, INTERGIS is advancing into the global logistics markets, such as in China, Brazil, Vietnam, Mexico, and the U.S. INTERGIS will consistently promote innovation in order to fulfill its vision of becoming a total logistics solution provider of the highest level of competitiveness.



Global Network

Dongkuk Steel is maximizing its synergies by operating branches and offices in the U.S., Japan, China, Brazil, India, Thailand, and Mexico.



- ✓ **Dongkuk International**
 19750 Magellan Drive Torrance, CA. 90502, U.S.A
 Tel 1-310-523-9595 FAX 1-310-523-9599
- ✓ **New York Office**
 400 Kelby Street, 11th Floor, Fort Lee, NJ 07024, U.S.A
 Tel 1-201-592-8600 FAX 1-201-947-3999
- ✓ **Companhia Siderúrgica do Pecém**
 Rodovia CE 422, S/N, Km 11.5, São Gonçalo do Amarante,
 CE, Brazil
 Tel 55-85-3033-3800 FAX 55-85-3033-3899
- ✓ **Dongkuk Corporation**
 7Floor, PMO Nihonbashi kayaba-cho, 3-11-10, Chuo-ku,
 Tokyo 103-0025, Japan
 Tel 81-3-5623-5723 FAX 81-3-5623-5722
- ✓ **Dongkuk Steel China**
 DONGKUK STEEL CHINA CO., LTD.
 中国江苏省江阴市夏街道港路5号三楼邮编
 3F, No.5 Sugang Rd., Xiagang Zone,
 Jiangyin City, Jiangsu, CHINA 214442
 Tel : 86-510-8603-7120 Fax : 86-510-8603-7122
- ✓ **DONGKUK STEEL INDIA PRIVATE LIMITED**
 B-3/2, Ecotech-1, Extension, Greater Noida, UP-201 308,
 India
 Tel 91-120-481-8156 FAX 91-813-037-6465
- ✓ **DONGKUK STEEL (THAILAND) LTD.**
 Pinthong Industrial Estate Project 3, No. 217/9 Moo 6,
 Bowin, Sriracha, Chonburi 20230, Thailand
 Tel 66-38-110-570 FAX 66-38-110-577
- ✓ **DONGKUK STEEL MEXICO SA DE CV**
 Av. Internacional #303 Parque Industrial Huinala, Apodaca,
 Nuevo Leon, Mexico C.P. 66645
 Tel 52-81-8145-2122 FAX 52-81-8145-4350

Sustainable Management

We are headed towards a future of sustainability.

We live to share our warmth with the world, and the Earth is our number one priority. That's why we believe wholeheartedly in mutual sustainability and mutual prosperity.

Dongkuk Steel is actively involved in diverse activities for continuing on a path towards sustainability.

01 Social Contributions

02 Environmental Management Activities

03 Fair Trade Activities



Sustainable Management Overview

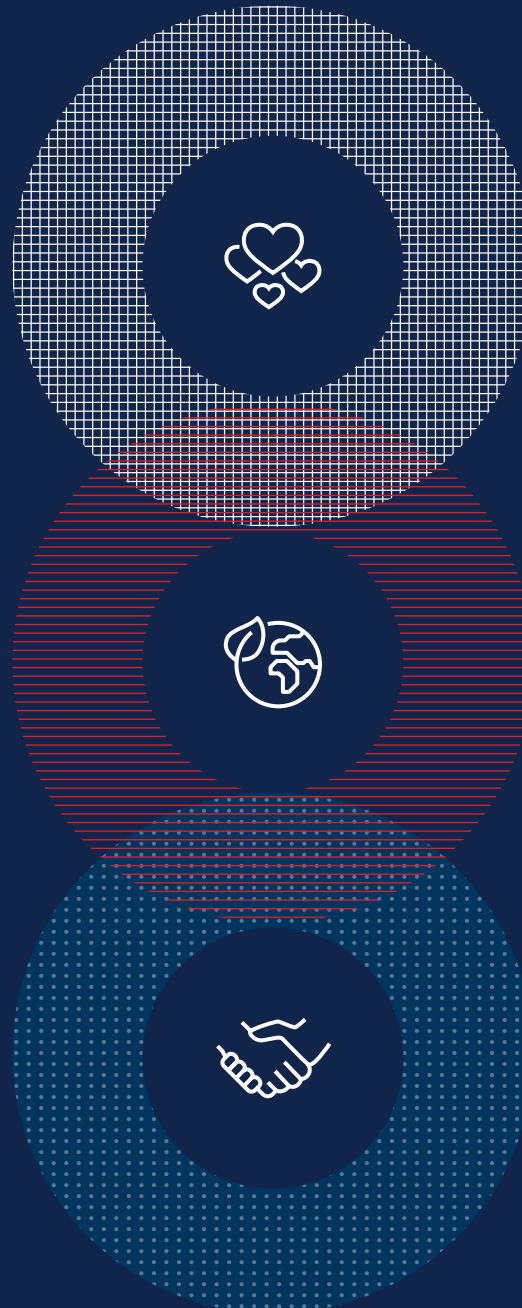

Social Contributions

- Volunteer Work for Local Communities
- Scholarship Project
- Cooperation with Social Enterprises

Environmental Management

- Steel making Using an Eco-friendly Electric Furnace
- Low-Carbon Society
- Green Action Plan 2020

Fair Trade

- Compliance Management
- Shared Growth

Social Contribution



Volunteer Work for Local Communities

“Nanum-Jiki” is a volunteer group composed of Dongkuk Steel’s employees. The group performs various social contribution activities including helping neighbors in need, sponsoring schools, and running environmental campaigns in Seoul, Pohang, Incheon, Dangjin, and Busan where the company’s branches and plants are located.



Scholarship Project

Since 2004, the Songwon Cultural Foundation, a subsidiary organization of Dongkuk Steel, has been providing scholarships for science and engineering students at colleges in the Gyeongin, Gyeongsang, Chungcheong, and Jeolla regions where the branches and plants of Dongkuk Steel are located in order to promote the advancement of science and engineering in Korea.

Dongkuk Steel also provides practical assistance to students through things such as preferential treatment in employment for students with excellent records who wish to join the company. In addition, since 2018, Dongkuk Steel has been supporting a scholarship project for the children of firefighters.



Cooperation with Social Enterprises

Through cooperation with Beautiful Store, a non-profit foundation, Dongkuk Steel is organizing sharing events and donating the proceeds to our neighbors in need. The company also practices sharing by donating items to Big Issue Korea in order to help promote the self-sufficiency of those vulnerable to housing issues.

Environmental Management Activities



Steel making Using an Eco-friendly Electric Furnace

Iron is an eco-friendly material that can be recycled at a rate exceeding 90%. Dongkuk Steel creates new products using scrapped iron and steel materials through the application of an eco-friendly electric furnace that uses steel scrap as a recyclable raw material.



Low-Carbon Society

Dongkuk Steel unsparingly invests in eco-friendly facilities and has bolstered its management system in response to climate change in order to continue to strive to reduce greenhouse gas emissions.



Green Action Plan 2020

To create an energy recycling and low-carbon society, all employees of Dongkuk Steel have dedicated their utmost to fulfilling the company's goals of improving the byproduct and water resource recycling rate and further reducing carbon emissions by 2020.

Fair Trade Activities



Compliance Management

Dongkuk Steel is operating a DK Compliance Program by installing a Compliance Office to promote compliance management and fair trade. The DK Compliance Program is Dongkuk Steel's compliance system which has been internally established and is operated to ensure that employees comply with fair trade-related laws. This program prevents losses resulting from the violation of laws by proposing behavioral criteria for employees and monitoring whether or not the criteria are met. It is also aimed at enhancing Dongkuk Steel's reliability, and thus improving the company's competitive power and sustainable growth.



Shared Growth

Since the declaration of the Fair Trade Agreement in 2017, Dongkuk Steel has been re-entering into the agreement with its partners annually. The Fair Trade Agreement is aimed at supporting the management activities of Dongkuk Steel's partners. Based on the agreement, Dongkuk Steel is building strong collaborative relationships with its partners.

CONTACT

Domestic workplace

» Head Office in Seoul

19, Eulji-ro 5-gil, Jung-gu, Seoul (Ferrum Tower)
02-317-1114

» Incheon Works

15, Jungbong-daero, Dong-gu, Incheon
032-830-6216

» Dangjin Works

25, Godaegongdan 1-gil Songak-eup, Dangjin-si,
Chungcheongnam-do
041-351-4984

» Doseong Center

23-36, Saetteo-ro Sinpyeong-myeon, Dangjin-si,
Chungcheongnam-do
041-351-4952

» Central Research Institute of Technology

70, Geonposaneop-ro 3214 beon-gil Daesong-myeon,
Nam-gu, Pohang-si, Gyeongsangbuk-do
054-271-2710

49, Namcheonseo-ro 20 beon-gil, Suyeong-gu, Busan
051-610-2300

» Pohang Works

195, Cheolgangsandan-ro, Daesong-myeon, Nam-gu,
Pohang-si, Gyeongsangbuk-do
054-278-6111

» Busan Works

102, Sinseon-ro, Nam-gu, Busan
051-640-5114

» Sinpyeong Works

76, Hasinbeonyeong-ro, Saha-gu, Busan
051-294-2133

Overseas Business

» Dongkuk International

19750 Magellan Drive Torrance, CA. 90502, U.S.A
Tel 1-310-523-9595 FAX 1-310-523-9599

» New York Office

400 Kelby Street, 11th Floor, Fort Lee, NJ 07024, U.S.A
Tel 1-201-592-8600 FAX 1-201-947-3999

» Companhia Siderúrgica do Pecém

Rodovia CE 422, S/N, Km 11.5, São Gonçalo do Amarante,
CE, Brazil
Tel 55-85-3033-3800 FAX 55-85-3033-3899

» Dongkuk Corporation

7Floor, PMO Nihonbashi kayaba-cho, 3-11-10, Chuo-ku,
Tokyo 103-0025, Japan
Tel 81-3-5623-5723 FAX 81-3-5623-5722

» Dongkuk Steel China

DONGKUK STEEL CHINA CO., LTD.
中国江苏省江阴市夏街道港路5号三楼邮编 3F, No.5 Sugang
Rd., Xiagang Zone, Jiangyin City, Jiangsu, CHINA 214442
Tel : 86-510-8603-7120 Fax : 86-510-8603-7122

» DONGKUK STEEL INDIA PRIVATE LIMITED

B-3/2, Ecotech-1, Extension, Greater Noida, UP-201 308,
India
Tel 91-120-481-8156 FAX 91-813-037-6465

» DONGKUK STEEL (THAILAND) LTD.

Pinthong Industrial Estate Project 3, No. 217/9 Moo 6,
Bowin, Sriracha, Chonburi 20230, Thailand
Tel 66-38-110-570 FAX 66-38-110-577

» DONGKUK STEEL MEXICO SA DE CV

Av. Internacional #303 Parque Industrial Huinala, Apodaca,
Nuevo Leon, Mexico C.P. 66645
Tel 52-81-8145-2122 FAX 52-81-8145-4350



19, Eulji-ro 5-gil, Jung-gu, Seoul (Ferrum Tower, Suha-dong)

02-317-1114